

Quick-Lift Rail

QL R 200i

Intelligent lifting device which meets the highest standards of ergonomics, working environment, safety and efficiency.

Unique integrated mechanical, electrical, pneumatic swivel enables continuous rotation of gripper.

Easy to use, thanks to outstanding responsiveness, regardless of load weight.

Exceptional safety is achieved using our intelligent control systems.

High cost efficiency through low power consumption, high reliability and long durability.



web: www.jenalex.ca | email: info@jenalex.ca

Ph: 1 800-536-2539 or 416-485-9487

BINAR
Improving your productivity

Quick-Lift Rail

QL R 200i

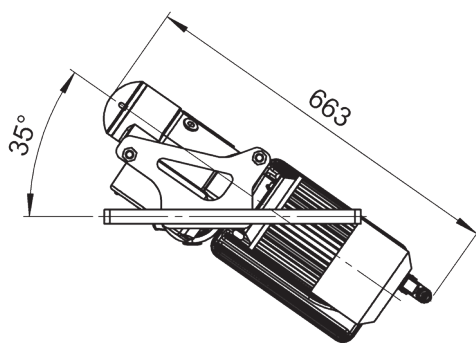
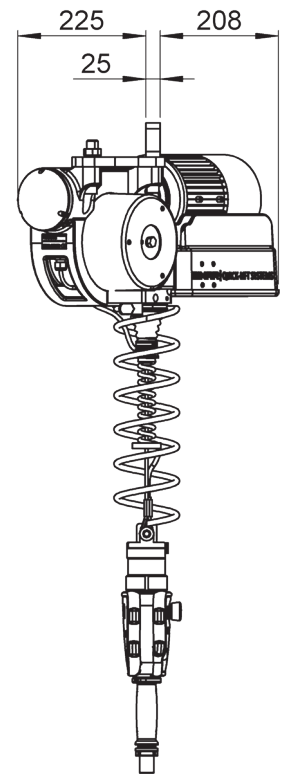
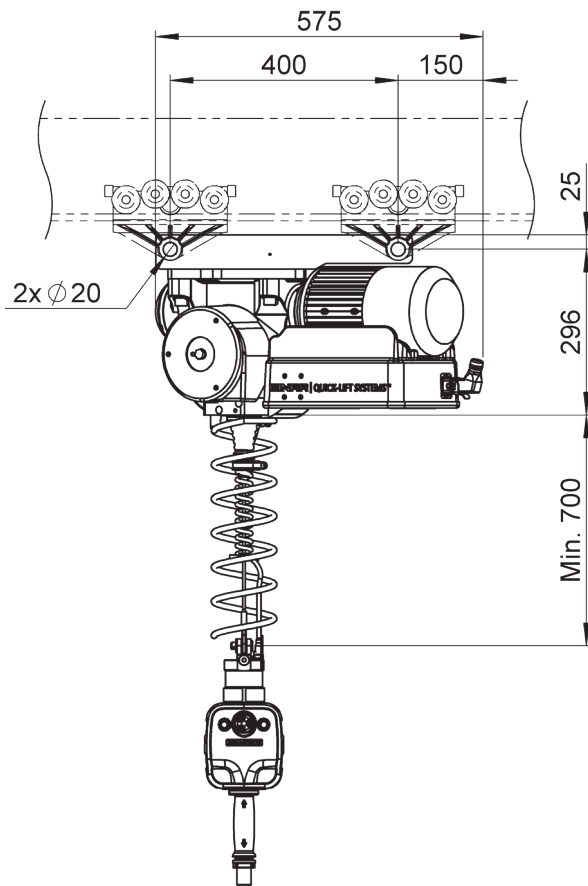

TECHNICAL DATA QL R 200i

Lifting capacity	Max 200 kg
Lift motor	Stepless servo-controlled asynchronous motor
Weight	43 kg
Manoeuvring	<p>Manoeuvring is done by using a patented manoeuvring handle or balancing mode. Both options sense the operator's hand/arm movement and give a very exact and smooth speed control.</p> <p>Only a force equivalent to 20 gram is needed to engage the up/down motion. When the operator let go of the handle or object, the up/down motion is immediately stopped.</p>
Power supply	230V, 50-60 Hz, 1-phase with ground protection, 10A
Stroke length	2,7 meter
Suspension	The QL R 200i can be mounted in the most common rail systems. Existing rail systems can often be used.
Gripping device	Grippers are designed to fit customer's need. Intelligent I/O signals are available for optimum functionality.

Binar Quick-Lift Systems AB disclaims responsibility for any errors or incomplete information in the published material and reserves the right to make changes.



Ergonomic Products

web: www.jenalex.ca | email: info@jenalex.ca

Ph: 1 800-536-2539 or 416-485-9487

BINAR
Improving your productivity